

## ScaleGard<sup>®</sup> Pro Softening Systems For Espresso Machines, Tea and Coffee Brewers



The new CUNO<sup>®</sup> SGP-124B & SGP-248B water filtration systems are designed to reduce hard scale build-up on espresso machine boilers, improve beverage quality and maintain efficient brewing machine operations.

High capacity ion exchange resin reduces calcium and magnesium to prevent hard scale. This exchange also creates an environment in which existing hard scale can actually be dissolved.

Premium activated carbon reduces chlorine taste and odor and bitterness associated with poor water quality.

The 1/4" NPT horizontal inlet and outlet ports are compatible with common equipment and tubing installations.

The SQC<sup>™</sup> - Sanitary Quick Change - encapsulated design reduces contamination during change-outs, are disposable and can be incinerated.

Single or dual cartridge systems allow for specific customization of filtration volume needs.

FDA CFR-21 and/or NSF compliant materials provide peace of mind that this product is suitable for potable applications.

---

### Hardness and Alkalinity Reduction with Chlorine Reduction

---

SGP-124B

Capacity: 421 gallons (1,594 liters) at 150 ppm (8.8 grains)

SGP-248B

Capacity: 842 gallons (3,187 liters) at 150 ppm (8.8 grains)

### Features

- High capacity ion exchange resin
- High capacity carbon
- Sanitary quick change design

### Benefits

- Reduces calcium, magnesium and alkalinity that form hard scale
- Creates an environment in which existing hard scale can be dissolved
- Extends equipment life
- Reduces chlorine taste and odor
- Improves beverage quality
- Reduces sediment
- Reduces clogging of nozzles and valves
- Does not require electrical connections, floor drain or backwashing in order to function

## Quotation for Specified CunoOCS® Water Filters

Specified Model # \_\_\_\_\_  
 Part # \_\_\_\_\_  
 Price Quoted \_\_\_\_\_  
 Installed on what equipment \_\_\_\_\_  
 \_\_\_\_\_  
 Quantity Required \_\_\_\_\_

For cold water use only. This product is for commercial use only. All materials are compliant with CFR title 21.

Do not use with water that is microbiologically unsafe or of unknown quality without adequate disinfection before or after the system.

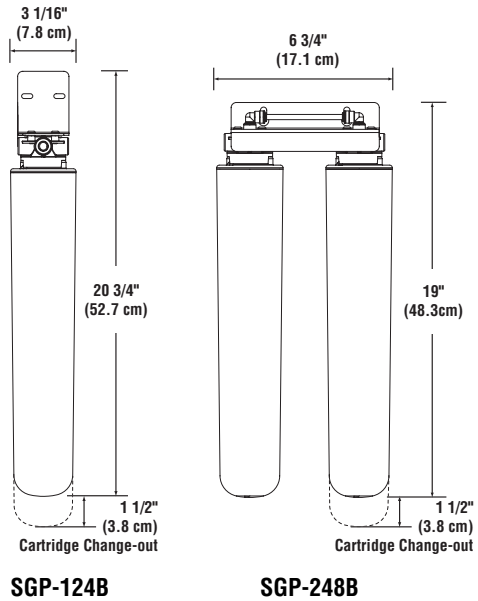

Trapezoid Performance Model

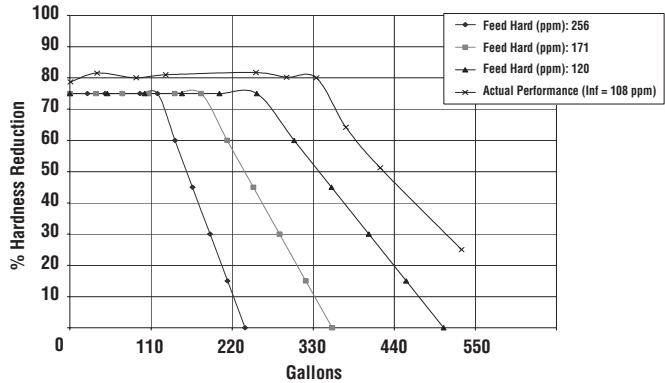

## Applications/Specifications

Model No.	Part No.	Replacement Cartridge	Part No.	Capacity	Flow Rate	Chlorine Taste and Odor	Scale Inhibition	Sediment Reduction	Heavy Sediment Reduction	Cyst Reduction	Turbidity Reduction	Carton Weight	Carton Dimensions	Case Qty.
SGP-124B	56089-02	P-124B (1 ea.)	56091-06	421 gallons (1,594 liters) at 150 ppm (8.8 grains)	0.5 gpm (1.9 lpm)	✓	✓	✓				12 lbs. (5.4 kg)	1.7 cu. ft. (0.05 cu. m)	4
SGP-248B	56090-02	P-124B (2 ea.)	56091-06	842 gallons (3,187 liters) at 150 ppm (8.8 grains)	1 gpm (3.8 lpm)	✓	✓	✓				8 lbs. (3.6 kg)	0.8 cu. ft. (0.02 cu. m)	1

## Distributed By:

## Limited 5 Year Warranty

CUNO Incorporated warrants to the original purchaser-consumer that this product is free from defects in materials and workmanship. This warranty, together with any and all warranties implied by law, shall be limited to a period of five (5) years from the date of original purchase by the consumer. This warranty does not apply to failures that result from abuse, misuse, alteration or damage not caused by CUNO. This warranty is subject to exclusions and limitations.

Please refer to the Warranty Card provided with the product for details.

## Service Worldwide

**China**  
 CUNO Filtration Shanghai Co. Ltd.  
 No. 2 Plant East Side  
 Xin Miao San Road  
 XinQiao Town SongJiang District  
 Shanghai, China 201612

**Australia**  
 CUNO Pacific Pty Ltd.  
 140 Sunnyholt Road  
 Blacktown, N.S.W. 2148  
 Australia

**Europe**  
 CUNO Limited  
 21 Woking Business Park  
 Albert Drive  
 Woking, Surrey  
 GU21 5JY, England



**Japan**  
 CUNO K.K.  
 Hodogaya Station Building 6F  
 1-7, Iwai-Cho, Hodogaya-Ku  
 Yokohama 240-0023, Japan

**Brazil**  
 CUNO Latina Ltda  
 Rua AMF do Brazil - 251  
 18120 Mairinque-SP, Brazil

**Singapore**  
 CUNO Filtration Asia Pte Ltd  
 18 Tuas Link 1  
 3rd Floor  
 Singapore 638599

**CUNO Incorporated**  
 400 Research Parkway  
 Meriden, CT 06450, USA  
 Toll Free: 1-888-218-CUNO  
 Worldwide: 203-237-5541  
 Fax: 203-238-8701  
 www.cuno.com