

SPEC # _____

QUANTITY _____

APPLICATION

COFFEE & ICE

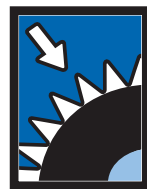

AT A GLANCE

Aqua-Pure[®] Models HF190-S and HF195-S single-cartridge water filtration systems help provide consistent high-quality water for commercial ice machines and coffee brewers by reducing potential harmful effects of sediment, chlorine, and scale at flow rates to 5.0 gpm (18.9 lpm). Built-in scale inhibition reduces the ability of calcium and magnesium to precipitate on the evaporator plates as hard scale.

- **HF190-S** combines chlorine taste and odor reduction with cyst, bacteria and sediment reduction, and helps provide equipment protection from the potentially harmful effects of chlorine corrosion and scale for up to 54,000 gallons (204,412 liters).
- **HF195-S** combines chlorine taste and odor reduction with sediment reduction for higher turbidity water and helps provide protection from the potentially harmful effects of chlorine corrosion and scale for up to 54,000 gallons (204,412 liters).

PRODUCT BENEFITS

- Effectively reduces sediment and chlorine for better equipment protection and clearer, great tasting, ice and coffee.
- Revolutionary Integrated **Membrane Pre-Activated Carbon Technology** (“**IMPACT**”) dual-zone media cartridge construction combines a membrane in series with premium activated carbon to provide superior throughput and cartridge life.
- Cartridge Life Warranted*.
- Certified by NSF to Standard 53 for cyst reduction (ICE190-S system).
- NSF Standard 42 and/or FDA CFR-21 compliant.
- Reduces up to 99.99% of common water-borne heterotrophic bacteria by membrane filtration as tested by CUNO (ICE190-S system).
- Built-in scale inhibitor reduces lime scale build-up on evaporator plates and heating coils, as tested by CUNO.
- SQC – Sanitary Quick Change – encapsulated cartridge design allows for fast and easy change-outs with a 1/4 turn while minimizing the possibility of leakage and contamination.
- 1/2" FNPT horizontal inlet and outlet ports allow direct or easily adaptable connections to existing plumbing lines.
- Exhausted cartridges may be incinerated.

PRODUCT SPECIFICATIONS

Model Number	Part Number	Reduction Claims	Micron Rating	Capacity	Service Flow Rate	Application	Replacement Cartridge
HF190-S	56164-03	Cyst, Bacteria, Sediment, Chlorine Taste and Odor, Scale	0.2'	54,000 gallons (204,412 liters)	5.0 gpm (18.9 lpm)	Most Normal Water	HF90-S: 56135-05
HF195-S	56164-04	Sediment, Chlorine Taste and Odor, Scale	3.0	54,000 gallons (204,412 liters)	5.0 gpm (18.9 lpm)	Higher Turbidity Water	HF95-S: 56135-09

* See Aqua-Pure Commercial Products Price Book for Terms and Conditions
 † NSF Certified for Particulate, Class I

Aqua-Pure® Commercial Products

SPEC # _____

QUANTITY _____

MODEL NUMBER _____

PART NUMBER _____

Aqua-Pure®
COMMERCIAL PRODUCTS
HF190-S/HF195-S

PHYSICAL SPECIFICATIONS

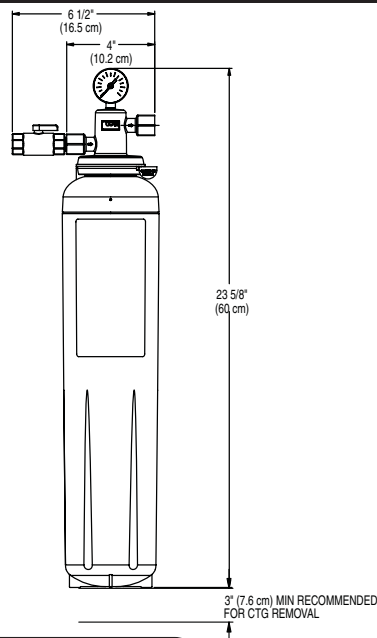

- System includes a head assembly with pressure gauge, inlet-water shut-off valve, mounting bracket, and single cartridge filter.
- Inlet and outlet plumbing connections are 1/2" FNPT.
- Filter cartridges are double o-ring seal type.
- System maximum operating temperature of 100°F (38°C).
- Recommended service flow rate is up to 5.0 gpm (18.9 lpm).
- Filter cartridges incorporate carbon block media protected by a pleated pre-filter membrane and a scale inhibitor.
- System is NSF Standard 42 and/or CFR-21 compliant.
- Cartridge body is constructed from high-impact glass-filled polypropylene.
- Cartridges are sanitary in design, requiring no contact with the filter media during cartridge change-out.
- Filter cartridges require no pre-activation.
- A NSF Performance Data Sheet (PDS) is included.
- Shipping weight: 5.8 lbs (2.6 kg)
- Operating weight: 11 lbs (5 kg)

IMPORTANT: INSTALLATION TIPS

- Shut off downstream equipment prior to installation of the system.
- Choose mounting location to support full system weight when operating.
- Do not exceed operating parameters for temperature or pressure.
- Do not install outdoors.
- For commercial use only
- Use on cold water line only.

WARNING: Do not use with water that is microbiologically unsafe or of unknown quality without adequate disinfection before or after the system. Systems certified for cyst reduction may be used on disinfected water that may contain filterable cysts. EPA Establishment Number 070595-CT-001.

CUNO Incorporated recommends regularly scheduled maintenance and replacement of the filter cartridge(s) in order for the product to perform as advertised/sold. **Change the filter cartridge at least every 6 months.** CUNO shall not be liable for system failures due to improper installation or maintenance.

LIMITED 5 YEAR WARRANTY

CUNO Incorporated makes no guarantees or warranties, expressed or implied, including, but not limited to, any implied warranty of merchantability or fitness for a particular purpose or implied warranty arising out of a course of dealing, custom, or usage of trade whatsoever with respect to these instructions. CUNO shall not under any circumstances be liable to the recipient of these instructions for any direct, indirect, special, incidental, or consequential loss or damages (including, but not limited to, loss of profits, revenue, business, opportunity, or goodwill) resulting from or in any way related to these instructions or the recipient's non-adherence to these instructions, regardless of the legal or equitable theory under which such loss or damages are sought, including breach of warranty or contract, negligence or strict liability.



Visit www.nsf.org for the claims associated with products that are NSF listed.



3M

CUNO Incorporated

400 Research Parkway
Meriden, CT 06450, USA
Toll Free: 1.888.218.CUNO
Worldwide: 203.237.5541
Fax: 203.238.8701

www.cunofoodservice.com