

Application

- Boiler Based Steamers
- Hot Water Heaters

Water Treatment Systems

Spec No. _____
Quantity _____



CFS440

Product Features

- ◆ 3/4" NPT inlet and outlet connections.
- ◆ Flow rate of 6 gpm (22.7 lpm) to accommodate point-of-entry applications.
- ◆ Polyphosphate/silicate combination coats surfaces to reduce scale formation.
- ◆ Venturi controlled dosage.
- ◆ Sanitary style cartridge for ease of change-out.

The CFS440 helps to reduce scale and corrosion on pipes, hot water heaters and other boiler applications. A combination of silicate and polyphosphate not only helps to reduce calcium and magnesium carbonates from forming a hard scale build-up, but also coats surfaces to help reduce the ability of hard scale to adhere. The venturi controlled dosing allows the system to perform for up to 6 months before change-out. The sanitary cartridge is easy to change and service.

Product Specifications

Model Number	Part Number	Description	Connections	Flow Rate	Cartridge Replacement
CFS440	55820-01	Venturi controlled dose scale inhibition system	3/4" Horizontal NPT Inlet & Outlet	Up to 6 gpm (22.7 lpm)	CFS441 (P/N 55821-01)



Water Filter Systems
Foodservice

CFS440 Water Treatment Systems

Spec No. _____
 Quantity _____
 Model Number _____
 Part Number _____

Physical Specifications:

- System to be dedicated scale reduction.
- System to be venturi controlled dosing style.
- Scale reduction material to be FDA CFR-21 and/or NSF compliant.
- System to have sanitary style cartridge.
- System to have maximum operating pressure of 125 psi (862 kPa) and operating temperature of 100°F (38°C).

Installation Tips:

- Shut off downstream equipment prior to installation of the system.
- Do not exceed operating parameters for temperature or pressure.
- Do not install outdoors.
- For cold water use only.
- For commercial use only.

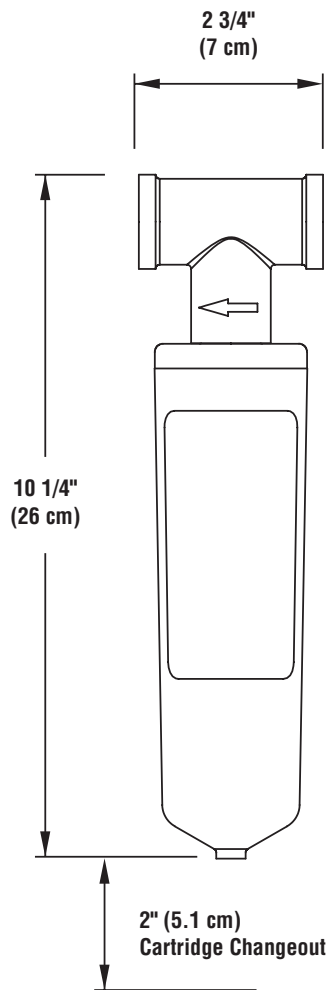

Do not use with water that is microbiologically unsafe or of unknown quality without adequate disinfection before or after the system.

CUNO Incorporated recommends regularly scheduled maintenance and replacement of the filter cartridge(s) in order for the product to perform as advertised/sold.

Limited 5 Year Warranty

CUNO Incorporated warrants to the original purchaser-consumer that this product is free from defects in materials and workmanship. This warranty, together with any and all warranties implied by law, shall be limited to a period of five (5) years from the date of original purchase by the consumer. This warranty does not apply to failures that result from abuse, misuse, alteration or damage not caused by CUNO. This warranty is subject to exclusions and limitations. Please refer to the Warranty Card provided with the product for details.

Service Worldwide

China
 CUNO Filtration Shanghai Co. Ltd.
 No. 2 Plant East Side
 Xin Miao San Road
 XinQiao Town SongJiang District
 Shanghai, China 201612

Australia
 CUNO Pacific Pty Ltd.
 140 Sunnyholt Road
 Blacktown, N.S.W. 2148
 Australia

Europe
 CUNO Limited
 21 Woking Business Park
 Albert Drive
 Woking, Surrey
 GU21 5JY, England



Japan
 CUNO K.K.
 Hodogaya Station Building 6F
 1-7, Iwai-Cho, Hodogaya-Ku
 Yokohama 240-0023, Japan

Brazil
 CUNO Latina Ltda
 Rua AMF do Brazil - 251
 18120 Mairinque-SP, Brazil

Singapore
 CUNO Filtration Asia Pte Ltd
 18 Tuas Link 1
 3rd Floor
 Singapore 638599

CUNO Incorporated
 400 Research Parkway
 Meriden, CT 06450, USA
 Toll Free: 1-888-218-CUNO
 Worldwide: 203-237-5541
 Fax: 203-238-8701